

DTP Beat Kit Pro 7

The DTP Beat Kit Pro 7 is an elite full-spectrum drum set designed for an ever growing number of professional drummers and sound engineers looking for a high-performance all-rounder kit that allows for reproducing authentic, powerful sound full of detail in any setting. From upscale studio projects to big live acts, the DTP Beat Kit Pro 7 provides just the kind of reliable premium gear you need for a memorable performance.

This 7-piece pro-kit contains our drum mic masterpiece, the dual-element cardioid DTP 640 REX, three dynamic DTP 340 TT mics, two LCT 340 condenser mics and one cardioid dynamic MTP 440 DM mic, as well as a selection of shock and drum mounts. All these pro-quality, precision-engineered microphones feature a tailored frequency response designed specifically for miking drums, percussions and bass instruments. The complete package exhibits fantastic SPL handling and off-axis sound rejection, delivering remarkably bright, smooth and balanced sound – anytime, anywhere.

The complete kit comes in a rugged aluminium case which allows for easy travel and secure storage.

Features / top applications

- 7-piece quality drum kit containing one DTP 640 REX, three dynamic DTP 340 TT microphones, two LCT 340 condenser microphones and one dynamic MTP 440 DM
- All microphones feature frequency responses specifically tailored for drums and percussion instruments
- Highly durable all-metal constructed bodies and hardened steel mesh grilles for reliable performance onstage and in the studio
- The LCT 340 provides interchangeable 0.8-inch small-diaphragm capsules for cardioid and omnidirectional (optional) pattern selection, convenient snap closure, transformerless output and dual-color LEDs
- The DTP 340 TT features a uniform supercardioid pickup pattern for high gain before feedback and maximum isolation of the desired sound source
- The MTP 440 DM is a cardioid dynamic microphone featuring a precision-engineered capsule for effective isolation of the intended sound source, perfectly suited for miking snare drums
- The DTP 640 REX combines a high-performance back-electret and a dynamic capsule in one mic for a highly balanced, rich and powerful drum sound
- All models are equipped with corrosion-resistant gold-plated 3-pin XLR output connectors ensuring reliable signal paths and low noise
- Comes in a black carrying case with double foam layers and artificial leather faces for easy travel and secure storage
- Includes two LCT 40 Ws windshields, five DTP 40 Mts shock mounts, four DTP 40 Mt drum mounts and one MTP 40 MCs shock mount



DTP 340 TT

Tech data

- Acoustical operating principle: dynamic, moving coil
- Directional pattern: super-cardioid
- Frequency range: 40 ... 16.000 Hz
- Sensitivity: 1,4 mV / Pa (-57 dBV)
- Rated impedance: < 500 ohms
- Connector: gold plated 3-pin XLR
- Dimensions: 41 dia. x 94 mm
1,6 dia. x 3,7 inch
- Net weight: 153 g
5,4 oz

Tech graph

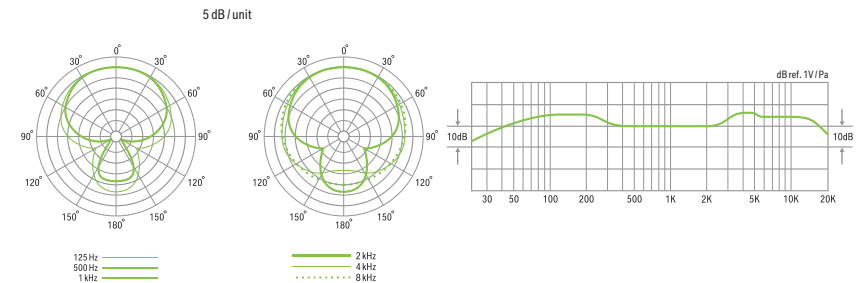

MTP 440 DM

Tech data

- Acoustical operating principle: dynamic, moving coil
- Directional pattern: cardioid
- Frequency range: 60 ... 16.000 Hz
- Sensitivity: 2,5 mV / Pa (-52 dBV)
- Rated impedance: < 500 ohms
- Connector: gold plated 3-pin XLR
- Dimensions: Ø 39 dia. x 159 mm
Ø 1,53 dia. x 6,25 inch
- Net weight: 280 g
9,88 oz

Tech graph

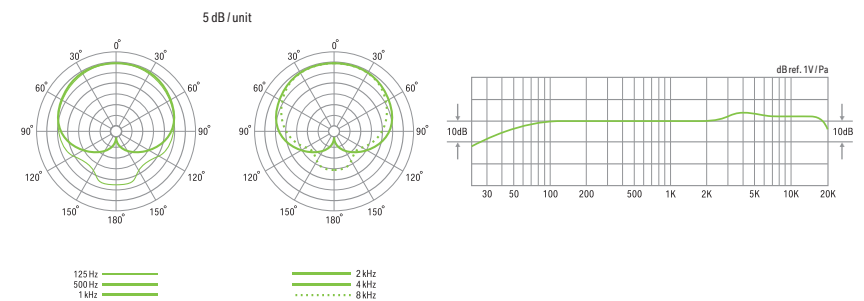

DTP 640 REX

Tech data

- Acoustical operating principle: dynamic, moving coil
condenser, permanently polarized
- Transducer Ø (dynamic): 31,7 mm
1,25 inch
- Transducer Ø (condenser): 22,4 mm
0,88 inch
- Directional pattern: cardioids, condenser and dynamic
- Frequency range: 20 ... 16.000 Hz, dynamic,
depending on EFR setting
20 ... 20.000 Hz, condenser,
depending on EFR setting
- EFR, 'Enhanced Frequency Response' settings:
= // = FFR, 'Flat Frequency Response'
+ // = Dynamic EFR, 'Dynamic Enhanced Frequency Response'
+ // + Dual EFR, 'Dual Enhanced Frequency Response'
- Sensitivity, = // = FFR: 0,4 mV / Pa (-69 dBV) dynamic
2 mV / Pa (-54 dBV) condenser
- Sensitivity, + // = Dynamic EFR: 0,4 mV / Pa (-69 dBV) dynamic
2 mV / Pa (-54 dBV) condense
- Sensitivity, + // + Dual EFR: condenser and dynamic matched at
1 mV / Pa (-60 dBV)
- Equivalent noise level: 28 dB-A (IEC 61672-1),
condenser, FFR
- Dynamic range of mic. amp.: 122 dB-A, condenser
- Max. SPL for 0,5 % THD: 150 dB, 0 dB pre-attenuation
160 dB, 10 dB pre-attenuation
170 dB, 20 dB pre-attenuation

Tech data

- Pre-attenuation pad: 10 dB, 20 dB, switchable
- Rated impedance: < 500 ohms, dynamic
< 200 ohms, condenser
- Supply voltage: 48 V + / - 4 V (IEC 61938)
- Current consumption: 2 mA (IEC 61938)
- Connector: gold plated 3-pin and 5-pin XLR
- Cable: 1,5 m (4,95') dual shielded Y-cable,
5-pin XLR into two 3-pin XLRs
- Dimensions: 71 dia. x 158 mm
2,8 dia. x 6,2 inch
- Net weight: 755 g
27,3 oz

Tech graph

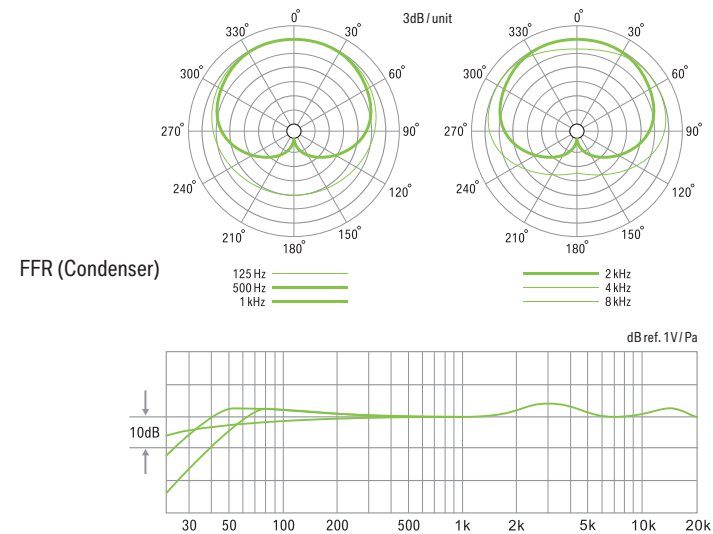

DTP 640 REX

Tech graph

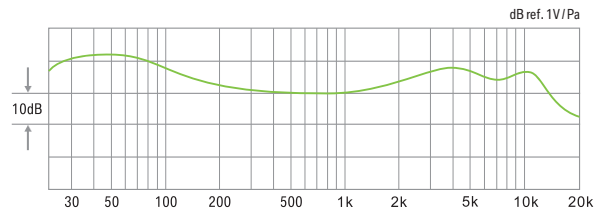
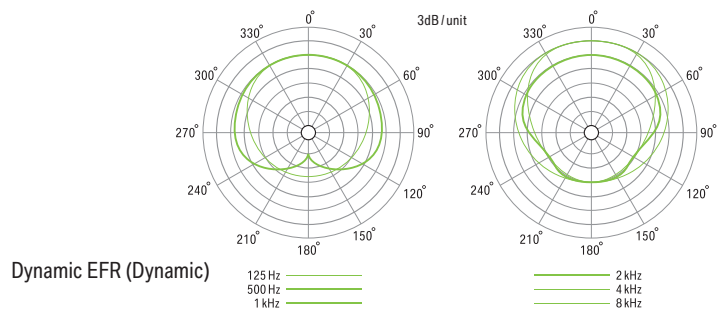
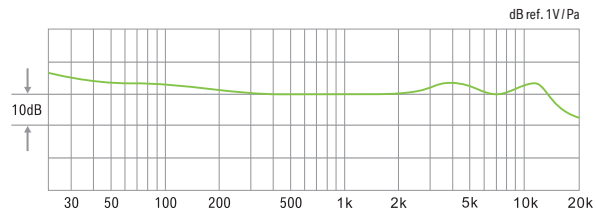
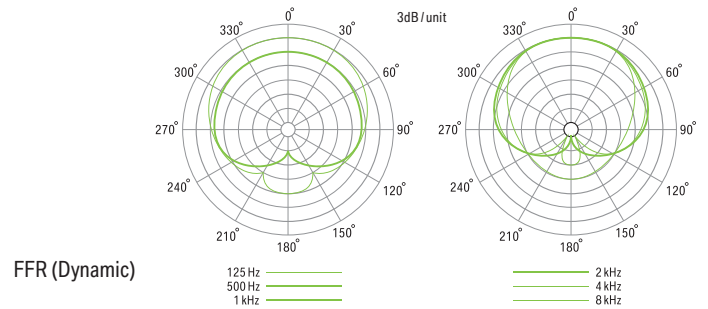

Tech graph

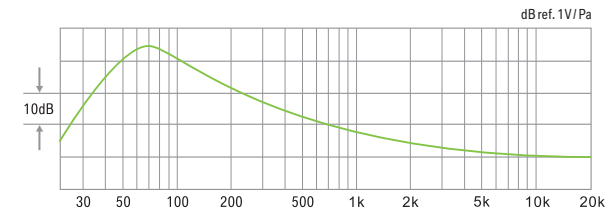
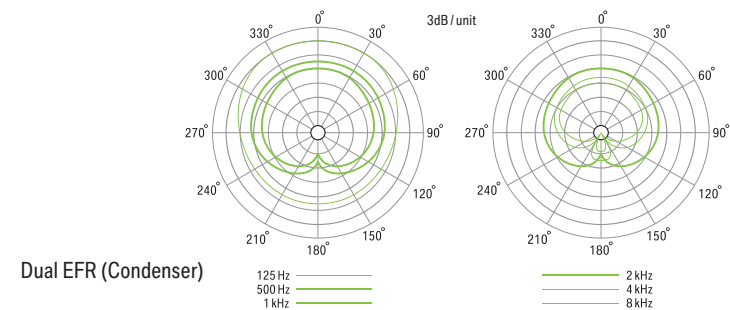
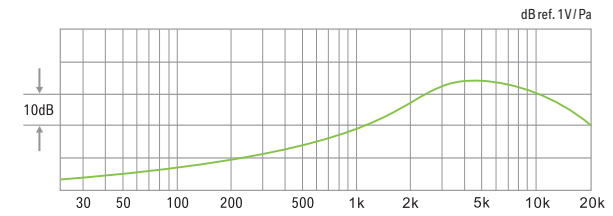
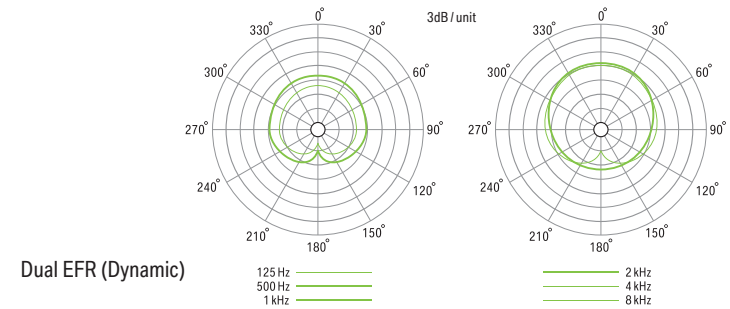

LCT 340

Tech data

- Acoustical operating principle: pressure & pressure gradient transducers, externally polarized
- Transducer \varnothing : 20,32 mm
0,8 inch
- Directional pattern: cardioid
Omni
- Frequency range: 20 ... 20.000 Hz
- Sensitivity: 9 mV / Pa (-41 dBV), cardioid
8 mV / Pa (-42 dBV), omni
- Signal / noise ratio: 79 dB-A
- Equivalent noise level: 15 dB-A, cardioid (IEC 61672-1)
16 dB-A, omni (IEC 61672-1)
- Dynamic range of mic. amp.: 124 dB-A
- Max. SPL for 0,5 % THD: 139 dB, 0 dB pre-attenuation
145 dB, 6 dB pre-attenuation
151 dB, 12 dB pre-attenuation
157 dB, 18 dB pre-attenuation
- Pre-attenuation pad: 6 dB, 12 dB, 18 dB, switchable
- Bass cut filter slope: 12 dB / octave at 40 Hz
6 dB / octave at 150 Hz
6 dB / octave at 300 Hz
- Rated impedance: < 150 ohms
- Rated load impedance: > 1.000 ohms
- Supply voltage: 48 V + / - 4 V (IEC 61938)
- Current consumption: 6,6 mA (IEC 61938)
- Connector: gold plated 3-pin XLR
- Dimensions: \varnothing 24 dia. x 160 mm
 \varnothing 0,94 dia. x 6,3 inch
- Net weight: 200 g
7,05 oz

Tech graph

