

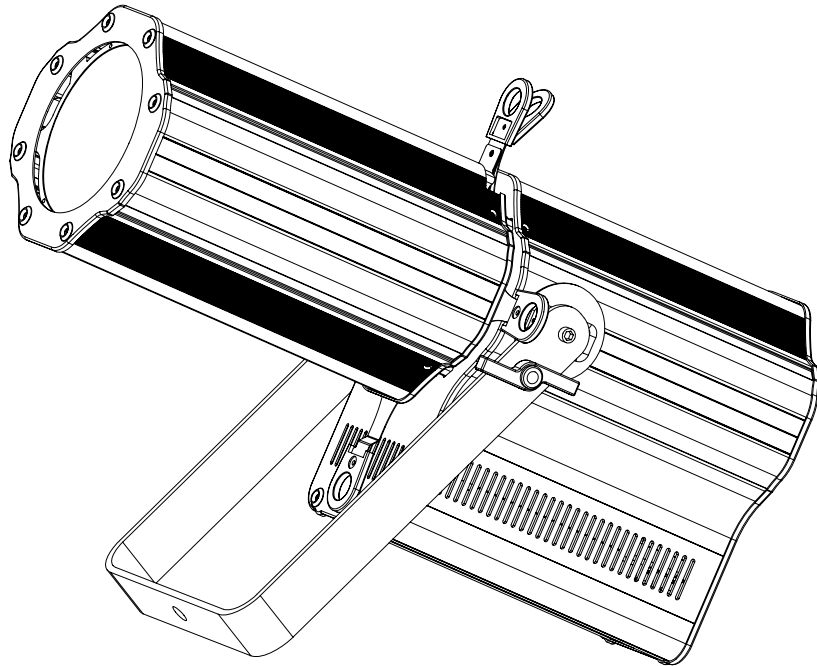

ENCORE PROFILE 1000 COLOR



User Instructions



©2016 ADJ Products, LLC all rights reserved. Information, specifications, diagrams, images, and instructions herein are subject to change without notice. ADJ Products, LLC logo and identifying product names and numbers herein are trademarks of ADJ Products, LLC. Copyright protection claimed includes all forms and matters of copyrightable materials and information now allowed by statutory or judicial law or hereinafter granted. Product names used in this document may be trademarks or registered trademarks of their respective companies and are hereby acknowledged. All non-ADJ Products, LLC brands and product names are trademarks or registered trademarks of their respective companies.

ADJ Products, LLC and all affiliated companies hereby disclaim any and all liabilities for property, equipment, building, and electrical damages, injuries to any persons, and direct or indirect economic loss associated with the use or reliance of any information contained within this document, and/or as a result of the improper, unsafe, insufficient and negligent assembly, installation, rigging, and operation of this product.

Europe Energy Saving Notice

Energy Saving Matters (EuP 2009/125/EC)

Saving electric energy is a key to help protecting the environment. Please turn off all electrical products when they are not in use. To avoid power consumption in idle mode, disconnect all electrical equipment from power when not in use. Thank you!

Encore Profile 1000 Color

Introduction

Unpacking: Thank you for purchasing the Encore Profile 1000 Color by ADJ Products, LLC. Every Encore Profile 1000 Color has been thoroughly tested and has been shipped in perfect operating condition. Carefully check the shipping carton for damage that may have occurred during shipping. If the carton appears to be damaged, carefully inspect your fixture for any damage and be sure all accessories necessary to operate the unit has arrived intact. In the case damage has been found or parts are missing, please contact our toll free customer support number for further instructions. Do not return this unit to your dealer without first contacting customer support.

Introduction: The ADJ Encore Profile 1000 Color is a DMX intelligent, high powered LED follow spot. This follow spot has five operating modes: RGBW dimmer mode, color change mode, color fade mode, auto run mode, static color mode, and DMX control mode. This fixture can be used in a stand alone mode or connected in a Master/Slave configuration. To optimize the performance of this product, please read these operating instructions carefully to familiarize yourself with the basic operations of this unit. These instructions contain important safety information regarding the use and maintenance of this unit. Please keep this manual with the unit, for future reference.

Customer Support: ADJ Products, LLC provides a customer support line, to provide set up help and to answer any question should you encounter problems during your set up or initial operation. You may also visit us on the web at www.adj.com for any comments or suggestions. Service Hours are Monday through Friday 8:00 a.m. to 4:30 p.m. Pacific Standard Time.

Voice: (800) 322-6337

Fax: (323) 582-2941

E-mail: support@AmericanDJ.com

Warning! To prevent or reduce the risk of electrical shock or fire, do not expose this unit to rain or moisture.

Caution! There are no user serviceable parts inside this unit. Do not attempt any repairs yourself, doing so will void your manufactures warranty. In the unlikely event your unit may require service please contact ADJ Products, LLC.

PLEASE recycle the shipping carton when ever possible.

Encore Profile 1000 Color

Features

- Five Operating Modes
- Electronic Dimming 0-100%
- 5 Selectable Dimming Curves
- 64 Color Macros
- 4 Included Gobos
- DMX-512 protocol
- Locking 3-Pin & 5-Pin XLR Connector In/Out
- 5 DMX Modes: 4 Channel Mode, 5 Channel Mode, 6 Channel Mode, 10 Channel Mode, & 11 Channel Mode.
- ADJ LED RC2, ADJ UC IR, (Not Included) & Airstream IR compatible
- Power Cord Daisy Chain (See page 27)

Encore Profile 1000 Color

Warranty Registration

The Encore Profile 1000 Color carries a 2 year limited warranty. Please fill out the enclosed warranty card to validate your purchase. All returned service items whether under warranty or not, must be freight pre-paid and accompany a return authorization (R.A.) number. The R.A. number must be clearly written on the outside of the return package. A brief description of the problem as well as the R.A. number must also be written down on a piece of paper included in the shipping carton. If the unit is under warranty, you must provide a copy of your proof of purchase invoice. You may obtain a R.A. number by contacting our customer support team on our customer support number. All packages returned to the service department not displaying a R.A. number on the outside of the package will be returned to the shipper.

Encore Profile 1000 Color

Installation

The unit should be mounted using a mounting clamp (not provided), affixing it to the mounting bracket that is provided with the unit. Always ensure that the unit is firmly fixed to avoid vibration and slipping while operating. Always ensure that the structure to which you are attaching the unit is secure and is able to support a weight of 10 times the unit's weight. Also, always use a safety cable that can hold 12 times the weight of the unit when installing the fixture. The equipment must be installed by a professional, and it must be installed in a place where it is out of the reach of people's grasp.

- To reduce the risk of electrical shock or fire, do not expose this unit rain or moisture
- Do not spill water or other liquids into or on to your unit.
- Do not attempt to operate this unit if the power cord has been frayed or broken. Do not attempt to remove or break off the ground prong from the electrical cord. This prong is used to reduce the risk of electrical shock and fire in case of an internal short.
- Disconnect from main power before making any type of connection.
- Do not remove the cover under any conditions. There are no user serviceable parts inside.
- Never operate this unit when it's cover is removed.
- Never plug this unit in to a dimmer pack
- Always be sure to mount this unit in an area that will allow proper ventilation. Allow about 6" (15cm) between this device and a wall.
- Do not attempt to operate this unit, if it becomes damaged.
- This unit is intended for indoor use only, use of this product out doors voids all warranties.
- During long periods of non-use, disconnect the unit's main power.
- Always mount this unit in safe and stable matter.
- Power-supply cords should be routed so that they are not likely to be walked on or pinched by items placed upon or against them, paying particular attention to the point they exit from the unit.
- Cleaning -The fixture should be cleaned only as recommended by the manufacturer. See page 27 for cleaning details.
- Heat -The appliance should be situated away from heat sources such as radiators, heat registers, stoves, or other appliances (including amplifiers) that produce heat.
- The fixture should be serviced by qualified service personnel when:
 - A. The power-supply cord or the plug has been damaged.
 - B. Objects have fallen, or liquid has been spilled into the appliance.
 - C. The appliance has been exposed to rain or water.
 - D. The appliance does not appear to operate normally or exhibits a marked change in performance.

Power Supply: The ADJ Encore Profile 1000 Color contains a automatic voltage switch, which will auto sense the voltage when it is plugged into the power source. With this switch there is no need to worry about the correct power voltage, this unit can be plugged in anywhere.

DMX-512: DMX is short for Digital Multiplex. This is a universal protocol used as a form of communication between intelligent fixtures and controllers. A DMX controller sends DMX data instructions from the controller to the fixture. DMX data is sent as serial data that travels from fixture to fixture via the DATA "IN" and DATA "OUT" XLR terminals located on all DMX fixtures (most controllers only have a DATA "OUT" terminal).

DMX Linking: DMX is a language allowing all makes and models of different manufactures to be linked together and operate from a single controller, as long as all fixtures and the controller are DMX compliant. To ensure proper DMX data transmission, when using several DMX fixtures try to use the shortest cable path possible. The order in which fixtures are connected in a DMX line does not influence the DMX addressing. For example; a fixture assigned a DMX address of 1 may be placed anywhere in a DMX line, at the beginning, at the end, or anywhere in the middle. When a fixture is assigned a DMX address of 1, the DMX controller knows to send DATA assigned to address 1 to that unit, no matter where it is located in the DMX chain.

Data Cable (DMX Cable) Requirements (For DMX Operation):

The Encore Profile 1000 Color can be controlled via DMX-512 protocol. The Encore Profile 1000 Color has 5 DMX modes, please see pages 9-10 for the different modes. The DMX address is set on the back panel of the

Encore Profile 1000 Color. Your unit and your DMX controller require a standard 3-pin or 5-pin XLR connector for data input and data output (Figure 1). We recommend Accu-Cable DMX cables. If you are making your own cables, be sure to use standard 110-120 Ohm shielded cable (This cable may be purchased at almost all pro lighting stores). Your cables should be made with a male and female XLR connector on either end of the cable. Also remember that DMX cable must be daisy chained and



Figure 1

cannot be split.

Notice: Be sure to follow figures two and three when making your own cables. Do not use the ground lug on the XLR connector. Do not connect the cable's shield conductor to the ground lug or allow the shield conductor to come in contact with the XLR's outer casing. Grounding the shield could cause a short circuit and erratic behavior.

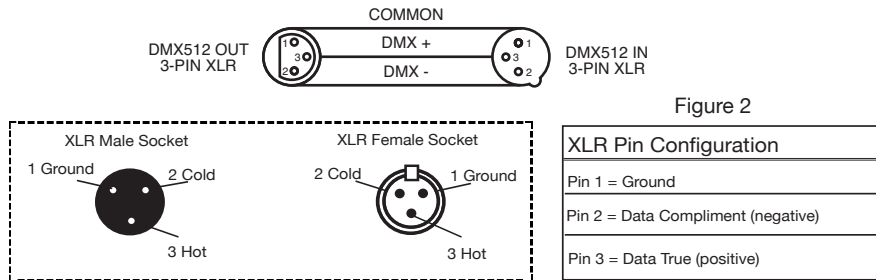

Figure 2

Figure 3

Special Note: Line Termination. When longer runs of cable are used, you may need to use a terminator on the last unit to avoid erratic behavior. A terminator is a 110-120 ohm 1/4 watt resistor which is connected between pins 2 and 3 of a male XLR connector (DATA + and DATA -). This unit is inserted in the female XLR connector of the last unit in your daisy chain to terminate the line. Using a cable terminator (ADJ part number Z-DMX/T) will decrease the possibilities of erratic behavior.



Termination reduces signal errors and avoids signal transmission problems and interference. It is always advisable to connect a DMX terminal, (Resistance 120 Ohm 1/4 W) between PIN 2 (DMX-) and PIN 3 (DMX +) of the last fixture.

Figure 4

5-Pin XLR DMX Connectors. Some manufactures use 5-pin DMX-512 data cables for DATA transmission in place of 3-pin. 5-pin DMX fixtures may be implemented in a 3-pin DMX line. When inserting standard 5-pin data cables in to a 3-pin line a cable adaptor must be used, these adaptors are readily available at most electric stores. The chart below details a proper cable conversion.

3-Pin XLR to 5-Pin XLR Conversion		
Conductor	3-Pin XLR Female (Out)	5-Pin XLR Male (In)
Ground/Shield	Pin 1	Pin 1
Data Compliment (- signal)	Pin 2	Pin 2
Data True (+ signal)	Pin 3	Pin 3
Not Used		Do Not Use
Not Used		Do Not Use

LCD Backlight On/Off:

To set the LCD backlight to turn off after 20 seconds, press the MODE button until "OTHER" is displayed, press the SET UP button until "OTHER BLGT:XX" is displayed. "XX" represents the current state. Press the UP or DOWN buttons to set the backlight to turn "OFF" after 20 seconds or "ON" to stay on at all times.

Operating Modes:

The Encore Profile 1000 Color has six operating modes:

- **RGBW Dimmer Mode** - Choose one of the four colors to remain static or adjust the intensity of each color to make your desired color.
- **Color Change mode** - There are 16 color change modes to choose from. In color change mode the unit will cycle through various colors depending on the color change mode that is chosen. The color change speed is also adjustable.
- **Color Fade mode** - There are 16 color fade modes to choose from. In color fade mode the unit will cycle/fade through various colors depending on the color fade mode that is chosen. The fade speed is also adjustable.
- **Auto Mode** - In Auto mode, the fixture will run a combination of color change and color fade. The speed is adjustable.
- **Static Color Mode** - There are 64 colors to choose from.
- **DMX control mode** - This function will allow you to control each individual fixtures traits with a standard DMX 512 controller.

RGBW Dimmer Mode:

1. Plug the fixture in and press the MODE button until "MANUAL" is displayed. Press the SET UP button to cycle through the RGBW colors.
2. When "RED" is displayed you are in Red dimming mode. Press the UP and DOWN buttons to adjust intensity.
3. When "GREN" is displayed you are in Green dimming mode. Press the UP and DOWN buttons to adjust intensity.
4. When "BLUE" is displayed you are in Blue dimming mode. Press the UP and DOWN buttons to adjust intensity.
5. When "WHIT" is displayed you are in White dimming mode. Press the UP and DOWN buttons to adjust intensity.

6. After you have adjusted the RGBW colors to make your desired color you can then activate strobing by pressing the SET UP button to enter strobing.
7. "STRO" will be displayed, this is strobing mode. The strobing can be adjusted between "00" (strobing off) to "15" (fastest strobing).

Color Change Mode:

1. Plug the fixture in and press the MODE button until "JUMP RUN SNAP:XX" is displayed. "XX" represents a number between 01-16.
2. Use the UP and DOWN buttons to find your desired color change mode.
3. Press the SET UP button and "SPEED:XX" will be displayed. Use the UP and DOWN buttons to adjust the speed of the color change. The speed can be adjusted between "01" (slowest) to "16" (fastest).

Color Fade Mode:

1. Plug the fixture in and press the MODE button until "FADE RUN FADE:XX" is displayed. "XX" represents a number between 01-16.
2. Use the UP and DOWN buttons to find your desired color fade mode.
3. Press the SET UP button and "SPEED:XX" will be displayed. Use the UP and DOWN buttons to adjust the speed of the color fade. The speed can be adjusted between "01" (slowest) to "16" (fastest).

Auto Run Mode:

1. Plug the fixture in and press the MODE button until "AUTO RUN FAD+SNAP" is displayed.
2. Press the SET UP button and "SPEED:XX" will be displayed. Use the UP and DOWN buttons to adjust the speed of the Auto Run. The speed can be adjusted between "01" (slowest) to "16" (fastest).

Static Color Mode:

1. Plug the fixture in and press the MODE button until "CLR MACS COLOR:XX" is displayed. "XX" represents a number between 00-64.
2. Use the UP and DOWN buttons to scroll through the 64 colors and find you desired color. After you have found your desired

- color you can activate strobing by pressing the SET UP button to enter the strobe mode.
3. "STROB:XX" will be displayed, this is strobe mode. The strobing can be adjusted between "00" (flash off) to "15" (fastest flash).

DMX Mode:

Operating through a DMX controller gives the user the freedom to create their own programs tailored to their own individual needs. The Encore Profile 1000 Color has 5 DMX modes: 4 channel mode, 5 channel mode, 6 channel mode, 10 channel mode, and 11 channel mode. See page's 17-23 for each mode's DMX traits.

1. This function will allow you to control each individual fixture's traits with a standard DMX 512 controller.
2. To run your fixture in DMX mode press the MODE button until "DMX MODE:XXX" is displayed. "XXX" represents the current displayed DMX address. Use the UP or DOWN buttons to select your desired DMX address, then press the SETUP button to select your DMX channel mode.
3. Use the UP or DOWN buttons to scroll through the DMX channel modes. The channel modes are listed below:
 - "CHAN: 04" is 4 Channel DMX Mode.
 - "CHAN: 05" is 5 Channel DMX Mode.
 - "CHAN: 06" is 6 Channel DMX Mode.
 - "CHAN: 10" is 10 Channel DMX Mode.
 - "CHAN: 11" is 11 Channel DMX Mode.
4. Please see pages 17-23 for DMX values and traits.
5. After you have chosen your desired DMX Channel mode plug in the fixture via the XLR connections to any standard DMX controller.

System Reset:

This will return the fixture to its factory settings.

1. Plug the fixture in and press the MODE button until "OTHER MODE" is displayed.
2. Press the SET UP button until "SYSRESET" is displayed.
3. Press the UP and DOWN buttons simultaneously to reset or press the MODE button to exit.

Dimmer Curve:

This is used to set the dimming curve used with DMX mode. See page 26 for the different dimming curves.

1. Plug the fixture in and press the MODE button until “DMX MODE ADDR:XXX” is displayed.
2. Press the SET UP button until “DELAY:X” is displayed. “X” represents the displayed dimmer curve (0-4).
 - 0 - Standard
 - 1 - Stage
 - 2 - TV
 - 3 - Architectural
 - 4 - Theatre
3. Press the UP or DOWN buttons to scroll through and select your desired dimming curve.

DMX State:

This mode can be used as a precaution mode, that in case the DMX signal is lost, the operating mode chosen in the setup is the running mode the fixture will go into when the DMX signal is lost. You can also set this as the operating mode you would like the unit to return to when power is applied.

1. Plug the fixture in and press the MODE button until “DMX MODE ADDR:XXX” is displayed.
2. Press the SET UP button until “DMX MODE NO” is displayed. The current DMX state will be displayed.
 - “BLACK” (Blackout) - If the DMX signal is lost or interrupted, the unit will automatically go into stand by mode.
 - “HOLD” (Last State) - If the DMX signal is lost or interrupted, the fixture will stay in the last DMX set up.
 - “AUTO” (Auto Run) - If the DMX signal is lost or interrupted, the unit will automatically go into Auto Run mode.
3. Press the UP or DOWN buttons to scroll through and select your desired DMX state.

ADJ RFC:

This function is used to activate and deactivate the infrared sensor. When this function is activated you can control the fixture using the ADJ LED RC2 (sold separately), UC IR (sold separately), and Airstream IR app. Please see pages 14-16 for remote controls and

functions. To control the Encore Profile 1000 Color, plug the included IR receiver into IR receiver input located on the rear of the controller. You must aim the remote at the IR sensor and be no more the 30 feet away.

1. Plug the fixture in and press the MODE button until “OTHER MODE” is displayed.
2. Press the SET UP button until “IR: XX” is displayed.
3. Press the UP or DOWN buttons to either activate the remote function (On) or deactivate it (Off).

Color Balance Mode:

1. Plug the fixture in and press the MODE button until “BALANCE” is displayed. Press the SET UP button for at least 3 seconds until the displayed number begins to flash.
2. When “RED” is displayed you are in Red balance mode. Press the UP and DOWN buttons to adjust intensity.
3. When “GREEN” is displayed you are in Green balance mode. Press the UP and DOWN buttons to adjust intensity.
4. When “BLUE” is displayed you are in Blue balance mode. Press the UP and DOWN buttons to adjust intensity.
5. When “WHIT” is displayed you are in White balance mode. Press the UP and DOWN buttons to adjust intensity.
6. Press the SET UP button for 3 seconds to save your settings.

Gamma:

This feature is predominately used when shooting video. Adjust the gamma setting to clean up any lines that might be seen on camera.

1. Plug the fixture in and press the MODE button until “GAMMA” is displayed. The current gamma setting will be displayed.
2. Use the UP and DOWN buttons to switch the gamma setting.

Refresh Rate:

This feature is predominately used when shooting video. Adjust the frequency setting to clear up any LED flicker that might be seen on camera.

1. Plug the fixture in and press the MODE button until “FREQUENC” is displayed. The current frequency setting will be displayed.
2. Use the UP and DOWN buttons to switch the frequency setting.

Fan Speed:

This will let you set your desired fan speed.

1. Plug the fixture in and press the MODE button until “FAN SPEED” is displayed, and press ENTER.
2. Use the UP and DOWN buttons to switch between the different fan speeds.

PCB Temperature:

This will check the current temperature of unit as well as switch between fahrenheit and celsius.

1. Plug the fixture in and press the MODE button until “OTHER MODE” is displayed.
2. Press the SET UP button until “TEM:XXXX” is displayed.
3. Use the UP and DOWN buttons to switch between fahrenheit and celsius.

Master-Slave Configuration:

This function will allow you to link units together to run in a Master-Slave setup. In a Master-Slave set up one unit will act as the controlling unit and the others will react to the controlling units built-in programs. Any unit can act as a Master or as a Slave however, only one unit can be programmed to act as the “Master.”

Master-Slave Connections and Settings:

1. Daisy chain your units via the XLR connector on the rear of the unit. Use standard XLR data cables to link your units together. Remember that the Male XLR connector is the input and the Female XLR connector is the output. The first unit in the chain (master) will use the female XLR connector only. The last unit in the chain will use the male XLR connector only.
2. Set the “Master” unit to your desired mode of operation.
3. On the “Slave” units press the MODE button until “Slave Mode” is displayed. The unit is now set as the “Slave” unit. Each slave unit must be set to the same setting.
4. Connect the first “Slave” unit to the “Master”, and the “Slave” unit should now start to follow the “Master”.

The knobs located on the right side of unit are used to adjust the focus and the zoom. For a tighter/narrow beam move the first/front knob to the front of the fixture, and move the second knob to rear. For a wider beam, move the first/front knob towards the middle of the fixture, and move the second knob towards the middle as well. Adjust accordingly.

The **ADJ LED RC2** infrared remote (sold separately) has many different functions to control your Encore Profile 1000 Color. To control the fixture you must aim the controller at the infrared sensor and be no more than 30 feet away. To use the ADJ LED RC2 you must first activate the fixture's infrared sensor, to activate the sensor please see the instructions on pages 10-11.

BLACKOUT - Pressing this button will blackout the fixture.

SELECT PROG - Pressing this button will cycle through static color mode, color change mode, color fade mode, and auto run mode. Each press of this button will change to the next mode. When you find your desired mode use the "+" or "-" to scroll through the programs or static colors. When in either color fade, or color change mode, press the Speed button and use the "+" or "-" to adjust the running speed. When in static color mode, press the Flash button to activate strobe and use the "+" or "-" to adjust the strobe speed.

FLASH - This button will activate the strobe effect. You can control the flash rate by pressing the "+" and "-" buttons. Press this button again to exit strobe mode.

SPEED - Press this button and use the "+" & "-" buttons to adjust the speed of the color change mode, color fade mode, and auto run.

DMX MODE - This button will cycle between DMX addressing, DMX channel mode, and dimmer curve selection. Some fixtures will come with different DMX channel modes. This button will switch between the different modes. Please see pages 16-22 for DMX modes, values, and traits.

SLAVE/SOUND ACTIVE - This designates the fixture as a slave fixture in a master/slave configuration. Sound activity is invalid for this fixture.

SET ADDRESS - Press this button to set the DMX address. Press this button first, then press the numbers to set the address. If the address is correctly set, all LED's will flash and the unit will automatically go into DMX mode.

Example: Set DMX Address 1 Press "S-0-0-1"
Set DMX Address 245 Press "S-2-4-5"

R G B W - Press either one of these buttons and then press the "+" or "-" to adjust the brightness. Press the FLASH button to activate strobing and use the "+" or "-" to adjust the flash speed.

"+" and "-" - These buttons adjust the flash rate and speed of the color change mode, color fade mode, and auto run. When in color change or color fade mode they are used to find your desired program. See color change mode and color fade mode on page 8.

DMX Mode:

Operating through a DMX controller gives the user the freedom to create their own programs tailored to their own individual needs. Follow the directions below to set your DMX address and DMX channel mode.

1. Before connecting to a DMX controller, your fixture has different DMX channel modes, please select your desired mode by pressing the DMX Mode button, then using the "+" or "-" buttons to scroll through the DMX channel modes. Set the mode before you address the fixture. See the bottom of this page for the different DMX modes.
2. After you have selected your mode, set the DMX address for the fixture by pressing the "S" button. When the "S" button is pressed the LED's will flash 2-3 times. Use the number buttons to press in your desired address. See **"SET ADDRESS"** on page 13 for examples.

Note: When setting the DMX address each time a number is pressed a LED color will flash, when you have set the DMX address correctly all LED's will flash 2-3 times.

3. Now you may connect the fixture via the XLR connections to any standard DMX controller. Please see pages 17-23 for a detailed description of the DMX modes, values, and traits.

- **If the Red LED flashes you are in 4 Channel Mode.**
- **If the Green LED flashes you are in 5 Channel Mode.**
- **If the Blue LED flashes you are in 6 Channel Mode.**
- **If the White LED flashes you are in 10 Channel Mode.**
- **If the Red & Green LED's flash you are in 11 Channel Mode.**

Encore Profile 1000 Color UC IR Remote & Airstream IR

The **UC IR (sold separately)** infrared remote gives you control of various functions (See below). To control the fixture you must aim the remote at the front of the fixture and be no more than 30 feet away.

The **Airstream IR (sold separately)** remote transmitter plugs into the headphone jack of your iOS phone or tablet. To control your IR fixture you must raise the volume to the maximum on your iOS phone or tablet and aim the transmitter at the fixture sensor and be no more than 15 feet away. After you have purchased the Airstream IR transmitters, the app is a free download from the app store for your iOS phone or tablet. The app comes with 3 pages of control depending on the fixture you are using. Please see below for IR functions including the corresponding app page.

Works with App page 1.

STAND BY - Pressing this button will blackout the fixture. Press the button again to return to the initial state.

FULL ON - Hold this button down to fully light up the unit. When you let the button go, the unit will return to its previous state.

FADE/GOBO - Pressing this button activates color fade mode. .

“DIMMER +” and “DIMMER -” - Use these buttons adjust output intensity in color mode.

STROBE - Press and hold this button for strobing.

COLOR - Press this button to activate color mode. Use buttons 1-9 to select your desired color. Use the “DIMMER+” and “DIMMER-” to scroll through the colors.

1-9 - Use these buttons to select your desired color or show when show mode is active. Use the “DIMMER+” and “DIMMER-” buttons to adjust the output intensity.

SHOW 0 - Press this button to activate show mode. Use buttons 1-9 to select shows 1-9. Press this button twice to run show 10, and press button 1 to run show 11.

Encore Profile 1000 Color 4 Channel Mode

Channel	Value	Function
1	0 - 255	RED 0% - 100%
2	0 - 255	GREEN 0% - 100%
3	0 - 255	BLUE 0% - 100%
4	0 - 255	WHITE 0% - 100%

Encore Profile 1000 Color 5 Channel Mode

Channel	Value	Function
1	0 - 255	RED 0% - 100%
2	0 - 255	GREEN 0% - 100%
3	0 - 255	BLUE 0% - 100%
4	0 - 255	WHITE 0% - 100%
5	0 - 255	MASTER DIMMER 0% - 100%

Encore Profile 1000 Color		6 Channel Mode
Channel	Value	Function
1	0 - 255	RED 0% - 100%
2	0 - 255	GREEN 0% - 100%
3	0 - 255	BLUE 0% - 100%
4	0 - 255	WHITE 0% - 100%
5	0 - 255	MASTER DIMMER 0% - 100%
6	0 - 15 16 - 255	SHUTTER/STROBE LED OFF STROBING SLOW - FAST

Encore Profile 1000 Color		10 Channel Mode
Channel	Value	Function
1	0 - 255	RED 0% - 100%
2	0 - 255	GREEN 0% - 100%
3	0 - 255	BLUE 0% - 100%
4	0 - 255	WHITE 0% - 100%
5	0 - 255	MASTER DIMMER 0% - 100%
6	0 - 15 16 - 255	SHUTTER/STROBE LED OFF STROBING SLOW - FAST
7	0 - 51 52 - 102 103 - 153 154 - 204 205 - 255	PROGRAM SELECTION MODE DIMMING MODE COLOR MACRO MODE COLOR CHANGE MODE COLOR FADE MODE AUTO RUN MODE
8	0 - 255 0 - 15 16 - 31 32 - 47 48 - 63 64 - 79 80 - 95 96 - 111 112 - 127 128 - 143 144 - 159 160 - 175 176 - 191	COLOR MACROS/PROGRAMS/ AUTO RUN COLOR MACRO MODE (See page 24 for the Color Macro Chart) COLOR CHANGE PROGRAMS COLOR CHANGE 1 COLOR CHANGE 2 COLOR CHANGE 3 COLOR CHANGE 4 COLOR CHANGE 5 COLOR CHANGE 6 COLOR CHANGE 7 COLOR CHANGE 8 COLOR CHANGE 9 COLOR CHANGE 10 COLOR CHANGE 11 COLOR CHANGE 12

Encore Profile 1000 Color		10 Channel Mode
Channel	Value	Function
8		COLOR MACROS/PROGRAMS/ AUTO RUN
		COLOR CHANGE PROGRAMS
	192 - 207	COLOR CHANGE 13
	208 - 223	COLOR CHANGE 14
	224 - 239	COLOR CHANGE 15
	240 - 255	COLOR CHANGE 16
		COLOR FADE PROGRAMS
	0 - 15	COLOR FADE 1
	16 - 31	COLOR FADE 2
	32 - 47	COLOR FADE 3
	48 - 63	COLOR FADE 4
	64 - 79	COLOR FADE 5
	80 - 95	COLOR FADE 6
	96 - 111	COLOR FADE 7
	112 - 127	COLOR FADE 8
	128 - 143	COLOR FADE 9
	144 - 159	COLOR FADE 10
	160 - 175	COLOR FADE 11
	176 - 191	COLOR FADE 12
	192 - 207	COLOR FADE 13
208 - 223	COLOR FADE 14	
224 - 239	COLOR FADE 15	
240 - 255	COLOR FADE 16	
9	0 - 255	PROGRAM SPEED SLOW - FAST
10	0 - 20	DIMMER CURVES STANDARD
	21 - 40	STAGE
	41 - 60	TV
	61 - 80	ARCHITECTURAL
	81 - 100	THEATRE
	101 - 255	DEFAULT TO UNIT SETTING

Encore Profile 1000 Color		11 Channel Mode
Channel	Value	Function
1	0 - 255	RED 0% - 100%
2	0 - 255	GREEN 0% - 100%
3	0 - 255	BLUE 0% - 100%
4	0 - 255	WHITE 0% - 100%
5	0 - 255	MASTER DIMMER 0% - 100%
6	0 - 15	STROBE
	16 - 255	LED OFF STROBING SLOW - FAST
7	0 - 51	PROGRAM SELECTION MODE
	52 - 102	DIMMING MODE
	103 - 153	COLOR MACRO MODE
	154 - 204	COLOR CHANGE MODE
	205 - 255	COLOR FADE MODE AUTO RUN MODE
8	0 - 255	COLOR MACROS/PROGRAMS/ AUTO RUN
		COLOR MACRO MODE (See page 24 for the Color Macro Chart)
		COLOR CHANGE PROGRAMS
	0 - 15	COLOR CHANGE 1
	16 - 31	COLOR CHANGE 2
	32 - 47	COLOR CHANGE 3
	48 - 63	COLOR CHANGE 4
	64 - 79	COLOR CHANGE 5
	80 - 95	COLOR CHANGE 6
	96 - 111	COLOR CHANGE 7
	112 - 127	COLOR CHANGE 8
	128 - 143	COLOR CHANGE 9
144 - 159	COLOR CHANGE 10	
160 - 175	COLOR CHANGE 11	
176 - 191	COLOR CHANGE 12	

Encore Profile 1000 Color		11 Channel Mode
Channel	Value	Function
8		COLOR MACROS/PROGRAMS/ AUTO RUN
		COLOR CHANGE PROGRAMS
	192 - 207	COLOR CHANGE 13
	208 - 223	COLOR CHANGE 14
	224 - 239	COLOR CHANGE 15
	240 - 255	COLOR CHANGE 16
		COLOR FADE PROGRAMS
	0 - 15	COLOR FADE 1
	16 - 31	COLOR FADE 2
	32 - 47	COLOR FADE 3
	48 - 63	COLOR FADE 4
	64 - 79	COLOR FADE 5
	80 - 95	COLOR FADE 6
	96 - 111	COLOR FADE 7
	112 - 127	COLOR FADE 8
	128 - 143	COLOR FADE 9
	144 - 159	COLOR FADE 10
	160 - 175	COLOR FADE 11
	176 - 191	COLOR FADE 12
	192 - 207	COLOR FADE 13
208 - 223	COLOR FADE 14	
224 - 239	COLOR FADE 15	
240 - 255	COLOR FADE 16	
9		PROGRAM SPEED
	0 - 255	SLOW - FAST
10		COLOR TEMPERATURE
	0 - 28	3200K
	29 - 57	3500K
	58 - 86	4200K
	87 - 114	4500K
	115 - 142	5200K
	143 - 170	5500K
	171 - 198	6200K
	199 - 226	6500K
227 - 255	7200K	

Encore Profile 1000 Color		11 Channel Mode
Channel	Value	Function
11		DIMMER CURVES
	0 - 20	STANDARD
	21 - 40	STAGE
	41 - 60	TV
	61 - 80	ARCHITECTURAL
	81 - 100	THEATRE
101 - 255	DEFAULT TO UNIT SETTING	

When Channel 7 is between the values of 0-51, Channels 1-4 are used, and Channel 6 will control strobing.

When Channel 7 is between the values of 52-102, Channel 8 is in Color Macros Mode, and Channel 6 will control strobing.

When Channel 7 is between the values of 103-153, Channel 8 is in Color Change Mode, and Channel 9 will control the color change speed.

When Channel 7 is between the values of 154-204, Channel 8 is in Color Fade Mode, and Channel 9 will control the color fade speed.

When Channel 7 is between the values of 205-255, Channel 8 is in Auto Run Mode, and Channel 9 will control the Auto Run speed.

Encore Profile 1000 Color

Color Macro Chart

Color No.	DMX VAU/L	RGBW COLOR INTENSITY				Color No.	DMX VAU/L	RGBW COLOR INTENSITY			
		RED	GREEN	BLUE	WHITE			RED	GREEN	BLUE	WHITE
OFF	0	0	0	0	0	Color33	129-132	255	206	143	0
Color1	1-4	80	255	234	80	Color34	133-136	254	177	153	0
Color2	5-8	80	255	164	80	Color35	137-140	254	192	138	0
Color3	9-12	77	255	112	77	Color36	141-144	254	165	98	0
Color4	13-16	117	255	83	83	Color37	145-148	254	121	0	0
Color5	17-20	160	255	77	77	Color38	149-152	176	17	0	0
Color6	21-24	223	255	83	83	Color39	153-156	96	0	11	0
Color7	25-28	255	243	77	77	Color40	157-160	234	139	171	0
Color8	29-32	255	200	74	74	Color41	161-164	224	5	97	0
Color9	33-36	255	166	77	77	Color42	165-168	175	77	173	0
Color10	37-40	255	125	74	74	Color43	169-172	119	130	199	0
Color11	41-44	255	97	77	74	Color44	173-176	147	164	212	0
Color12	45-48	255	71	77	71	Color45	177-180	88	2	163	0
Color13	49-52	255	83	134	83	Color46	181-184	0	38	86	0
Color14	53-56	255	93	182	93	Color47	185-188	0	142	208	0
Color15	57-60	255	96	236	96	Color48	189-192	52	148	209	0
Color16	61-64	238	93	255	93	Color49	193-196	1	134	201	0
Color17	65-68	196	87	255	87	Color50	197-200	0	145	212	0
Color18	69-72	150	90	255	90	Color51	201-204	0	121	192	0
Color19	73-76	100	77	255	77	Color52	205-208	0	129	184	0
Color20	77-80	77	100	255	77	Color53	209-212	0	83	115	0
Color21	81-84	67	148	255	67	Color54	213-216	0	97	166	0
Color22	85-88	77	195	255	77	Color55	217-220	1	100	167	0
Color23	89-92	77	234	255	77	Color56	221-224	0	40	86	0
Color24	93-96	158	255	144	144	Color57	225-228	209	219	182	0
Color25	97-100	255	251	153	153	Color58	229-232	42	165	85	0
Color26	101-104	255	175	147	147	Color59	233-236	0	46	35	0
Color27	105-108	255	138	186	138	Color60	237-240	8	107	222	0
Color28	109-112	255	147	251	147	Color61	241-244	107	156	231	0
Color29	113-116	151	138	255	138	Color62	245-248	165	198	247	0
Color30	117-120	66	0	255	100	Color63	249-252	0	0	189	0
Color31	121-124	138	169	255	138	Color64	253-255	255	255	255	0
Color32	125-128	255	255	255	255						

Encore Profile 1000 Color

CAD Drawing

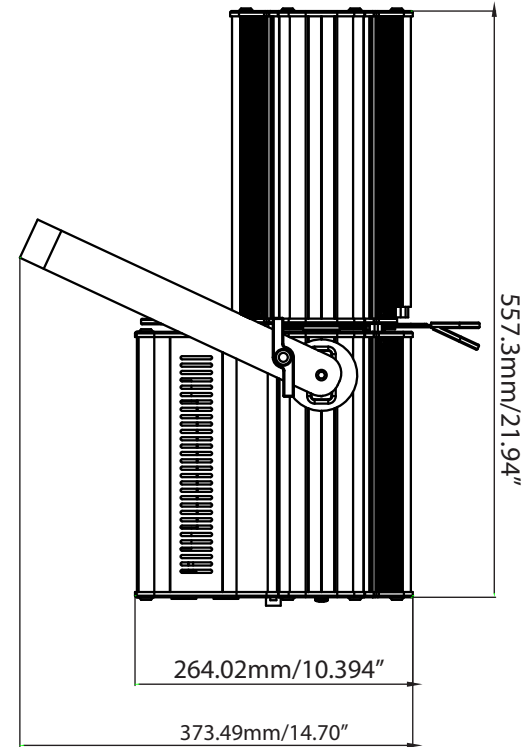
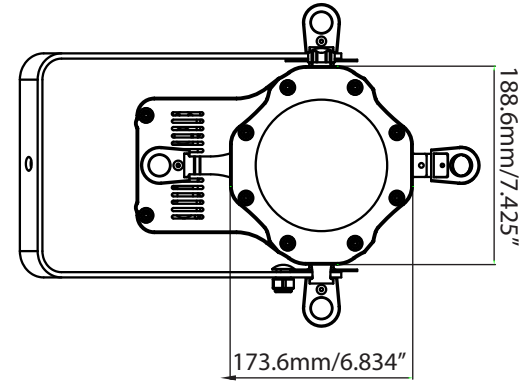

Encore Profile 1000 Color

Gobo Install

The Encore Profile 1000 Color comes with 4 replaceable gobos (see below). To install a gobo, unscrew and remove the phillips screw located at the bottom of the gobo holder. Gently lift part of the gobo holder side up and carefully slide the gobo into place. Reinstall the philips and screw and tighten. Slide the gobo holder into the slot located at the top of the unit in front of the framing lever.



Encore Profile 1000 Color

Dimmer Curve Chart

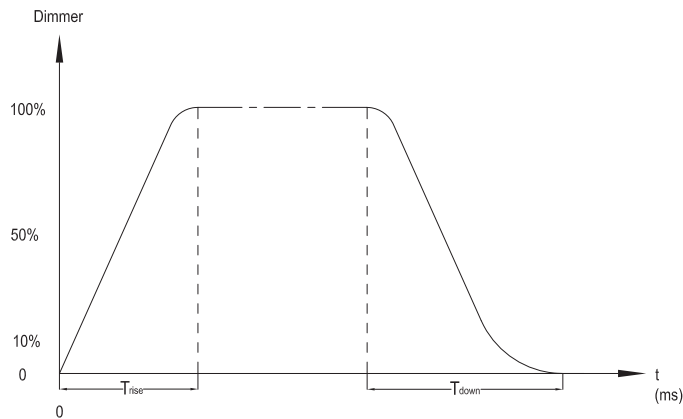

Ramp Effect	OS (Fade Time)		1S (Fade Time)	
	T_{rise} (ms)	T_{down} (ms)	T_{rise} (ms)	T_{down} (ms)
Standard	0	0	0	0
Stage	780	1100	1540	1660
TV	1180	1520	1860	1940
Architectural	1380	1730	2040	2120
Theatre	1580	1940	2230	2280

Encore Profile 1000 Color

Power Cord Daisy Chain

With this feature you can connect the fixtures to one another using the locking power input and output sockets. The quantity that can be connected is 5 fixtures maximum. After 5 fixtures you will need to use a new power outlet. They must be the same fixtures. DO NOT mix fixtures.

Encore Profile 1000 Color

Fuse Replacement

Disconnect the unit from its power source. Remove the power cord from the unit. Once the cord has been removed, the fuse holder is located above the power connection. Use a phillips head screwdriver to remove the fuse holder. Remove the fuse located inside the fuse holder and replace with the new fuse. Install the fuse holder and new fuse and secure it.

Encore Profile 1000 Color

Trouble Shooting

Listed below are a few common problems the user may encounter, with solutions.

Unit not responding to DMX:

1. Check that the DMX cables are connected properly and are wired correctly (pin 3 is "hot"; on some other DMX devices pin 2 may be 'hot'). Also, check that all cables are connected to the right connectors; it does matter which way the inputs and outputs are connected.

Encore Profile 1000 Color

Cleaning

Due to fog residue, smoke, and dust cleaning the internal and external optical lenses must be carried out periodically to optimize light output.

1. Use normal glass cleaner and a soft cloth to wipe down the outside casing.
2. Clean the external optics with glass cleaner and a soft cloth every 20 days.
3. Always be sure to dry all parts completely before plugging the unit back in.

Cleaning frequency depends on the environment in which the fixture operates (i.e. smoke, fog residue, dust, dew).

MANUFACTURER'S LIMITED WARRANTY

- A. ADJ Products, LLC hereby warrants, to the original purchaser, ADJ Products, LLC products to be free of manufacturing defects in material and workmanship for a prescribed period from the date of purchase (see specific warranty period on reverse). This warranty shall be valid only if the product is purchased within the United States of America, including possessions and territories. It is the owner's responsibility to establish the date and place of purchase by acceptable evidence, at the time service is sought.
- B. For warranty service you must obtain a Return Authorization number (RA#) before sending back the product—please contact ADJ Products, LLC Service Department at 800-322-6337. Send the product only to the ADJ Products, LLC factory. All shipping charges must be pre-paid. If the requested repairs or service (including parts replacement) are within the terms of this warranty, ADJ Products, LLC will pay return shipping charges only to a designated point within the United States. If the entire instrument is sent, it must be shipped in its original package. No accessories should be shipped with the product. If any accessories are shipped with the product, ADJ Products, LLC shall have no liability whatsoever for loss of or damage to any such accessories, nor for the safe return thereof.
- C. This warranty is void if the serial number has been altered or removed; if the product is modified in any manner which ADJ Products, LLC concludes, after inspection, affects the reliability of the product; if the product has been repaired or serviced by anyone other than the ADJ Products, LLC factory unless prior written authorization was issued to purchaser by ADJ Products, LLC; if the product is damaged because not properly maintained as set forth in the instruction manual.
- D. This is not a service contract, and this warranty does not include maintenance, cleaning or periodic check up. During the period specified above, ADJ Products, LLC will replace defective parts at its expense with new or refurbished parts, and will absorb all expenses for warranty service and repair labor by reason of defects in material or workmanship. The sole responsibility of ADJ Products, LLC under this warranty shall be limited to the repair of the product, or replacement thereof, including parts, at the sole discretion of ADJ Products, LLC. All products covered by this warranty were manufactured after August 15, 2012, and bear identifying marks to that effect.
- E. ADJ Products, LLC reserves the right to make changes in design and/or improvements upon its products without any obligation to include these changes in any products theretofore manufactured.

No warranty, whether expressed or implied, is given or made with respect to any accessory supplied with products described above. Except to the extent prohibited by applicable law, all implied warranties made by ADJ Products, LLC in connection with this product, including warranties of merchantability or fitness, are limited in duration to the warranty period set forth above. And no warranties, whether expressed or implied, including warranties of merchantability or fitness, shall apply to this product after said period has expired. The consumer's and/or Dealer's sole remedy shall be such repair or replacement as is expressly provided above; and under no circumstances shall ADJ Products, LLC be liable for any loss or damage, direct or consequential, arising out of the use of, or inability to use, this product.

This warranty is the only written warranty applicable to ADJ Products, LLC Products and supersedes all prior warranties and written descriptions of warranty terms and conditions heretofore published.

MANUFACTURER'S LIMITED WARRANTY PERIODS:

- **Lighting Products = 1-year (365 days) Limited Warranty** (Such as: Special Effect Lighting, Intelligent Lighting, UV lighting, Stobes, Fog Machines, Bubble Machines, Mirror Balls, Par Cans, Trussing, Lighting Stands etc. excluding LED and lamps)
- **Laser Products = 1 Year (365 Days) Limited Warranty** (excluding laser diodes which have a 6 month limited warranty)
- **L.E.D. Products = 2-year (730 days) Limited Warranty** (excluding motors, PCB boards, and power supplies, which have a 1-year (365 day Limited Warranty) batteries which have a 180 day limited warranty). Only the L.E.D.s carry a 2-year warranty (excluding StarTec Series which carries a 1 Year Limited Warranty) **Note: 2 Year Warranty only applies to purchases within the United States.**
- **ADJ DMX Controllers = 2 Year (730 Days) Limited Warranty** (excluding faders and tact switches)

Model: Encore Profile 1000 Color

Voltage:	100V ~ 240V/50~60Hz
LEDs:	1 x 120W RGBw 4-in-1 COB LED
Working Position:	Any safe working position
Power Draw:	144W
Power Cord Daisy Chain:	5 Fixtures Max.
Fuse:	3 Amp
Weight:	19 lbs./ 8.5Kgs.
Dimensions:	22" (L) x 9.75" (W) x 15.25" (H) 560 x 250 x 385mm
Colors:	RGBW Mixing
Gobo Size:	Outer Diameter: 61mm Inner Diameter: 51mm Thickness: 2mm
DMX Channels:	5 DMX Modes: 4 Channel Mode, 5 Channel Mode, 6 Channel Mode, 10 Channel Mode, & 11 Channel Mode
Warranty:	2 Year (730 days)

Auto Sensing Voltage: This fixture contains a automatic voltage switch, which will auto sense the voltage when it is plugged into the power source.

Please Note: Specifications and improvements in the design of this unit and this manual are subject to change without any prior written notice.

ADJ Products, LLC
6122 S. Eastern Ave. Los Angeles, CA 90040 USA
Tel: 323-582-2650 / Fax: 323-725-6100
Web: www.adj.com / E-mail: info@americandj.com

A.D.J. Supply Europe B.V.
Junostraat 2
6468 EW Kerkrade
The Netherlands

Follow Us On:



facebook.com/americandj
twitter.com/americandj
youtube.com/adjlighting

service@adjgroup.eu / www.adj.eu
Tel: +31 45 546 85 00 / Fax: +31 45 546 85 99