

# Quam SYSTEM 7DT

SYSTEM 7DT is a complete menu board loudspeaker system consisting of a 4" O.D., square frame loudspeaker with 5 oz. magnet, 8 Ohm impedance, and a multiple position "U" bracket. Black powder coat finish. The SYSTEM 7DT is designed for drive-thru ordering applications.

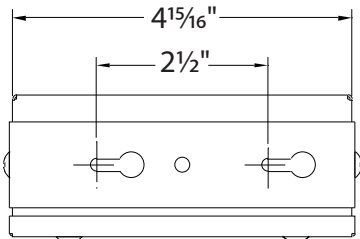

<b>APPLICATION</b>	<b>Intended Use:</b> <b>Program Material:</b> <b>Installation:</b>	Indoor or protected outdoor environment Voice and signal tones Vertical surface mount, downward firing
<b>AUDIO PERFORMANCE</b>	<b>Average Sensitivity:</b> <b>Loudspeaker Power Rating:</b> <b>Calculated Output:</b> <b>Magnet Type &amp; Weight:</b> <b>Frequency Response:</b> <b>Nominal Coverage Angle:</b> <b>Audio Connection:</b>	91dB SPL, 1W/1M 10W RMS, EIA 426A Standard 121 dB SPL, 5W/1M BeFe Ceramic, 4.8 oz. Nominal 130Hz - 17kHz EIA, 426A Standard 90° Included Angle, -6dB/2kHz, Half Space 15", Color-coded, Pre-tinned Leads
<b>COMPONENT</b>	<b>Dimensions:</b> <b>Weight:</b> <b>Loudspeaker Type:</b> <b>Transformer:</b> <b>Finish:</b> <b>Other:</b>	5 1/16" (H) x 5 1/16" (W) x 2 3/16" (D) 3 lbs. 4C3Z80T 8 Ohm Black powder coat Multiple position "U" bracket



TOP

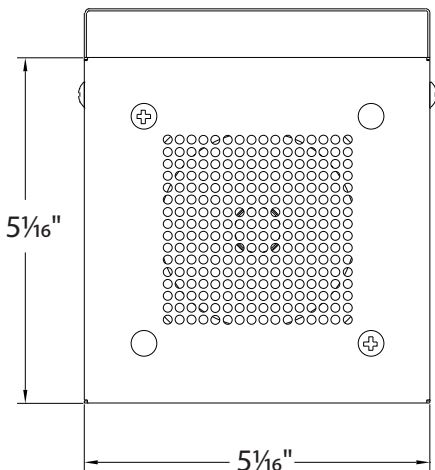

FRONT

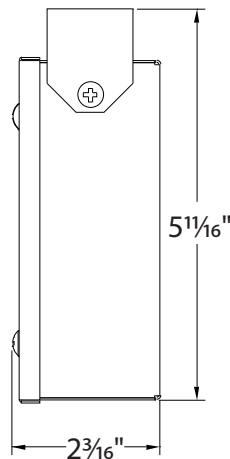

SIDE

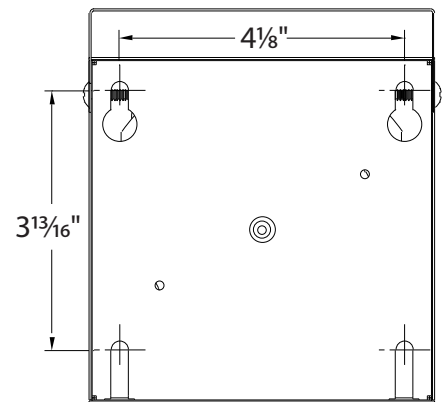

BACK